



# Mapelastic® AquaDefense

## Premium Waterproofing and Crack-Isolation Membrane



### DESCRIPTION

*Mapelastic AquaDefense* is a premixed, advanced liquid-rubber, extremely quick-drying waterproofing and crack-isolation membrane for installation under ceramic tile or stone in residential, commercial and industrial environments. *Mapelastic AquaDefense* provides a thin, continuous barrier to protect adjacent rooms and floors below from water damage. For common problem areas like coves, corners, cracks and drains, it can be combined with MAPEI's optional *Reinforcing Fabric* or *Mapeband™* accessories (cove roll and drain flash) to provide additional protection. *Mapelastic AquaDefense* dries after about 30 to 50 minutes and is then ready to receive any MAPEI polymer or epoxy mortar. *Mapelastic AquaDefense* can be flood-tested after 12 hours of drying time, is IAPMO-listed for use as a shower-pan liner, and exceeds ANSI A118.10 and ANSI A118.12 standards.

### FEATURES AND BENEFITS

- Very quick drying: Install tile after 30 to 50 minutes of drying time.
- Time-saving: Flood-test as shower-pan liner after 12 hours of drying time.
- Apply with roller or brush – easy to install over flat, curved or irregular surfaces
- Bonds to a wide range of surfaces; convenient, user-friendly and versatile
- No odor; great for confined spaces
- Prevents in-plane floor cracks from transmitting through tile or stone

### INDUSTRY STANDARDS AND APPROVALS

- ANSI: Exceeds A118.10 standard (Waterproofing Membranes for Thin-Set Ceramic Tile) and A118.12 standard (Crack-Isolation Membranes for Thin-Set Ceramic Tile)

- ASTM: C627 (Robinson) service rating of Extra Heavy
- ASTM: E96, Procedure E (Desiccant Method) at 100°F (37.8°C), meeting requirements of < 0.5 perms
- IAPMO: Listed for use as shower-pan liner
- IAPMO File #3996
- ICC Evaluation Service Report ESR 3474

### WHERE TO USE

- Residential and commercial interior/exterior floors, walls and ceilings
- Industrial interior floors and walls
- Tub and shower surrounds: Bathrooms; kitchens; food prep, dishwashing, servery and cafeteria areas; countertops; and laundry rooms
- Residential and commercial submerged applications: Freshwater pools, fountains and water features (completely covered by ceramic tile)
- Cantilevered balconies and decks over unoccupied space (see the "Limitations" section below)
- Balconies and decks over occupied space when used in conjunction with a primary waterproofing membrane
- Steam rooms and steam showers (refer to TCNA handbook's sections SR613 and SR614, or TTMAC 319SR and 321SR)
- Meets ASTM E96 Procedure E for a low-perm waterproof membrane
- In-plane crack isolation up to 1/8" (3 mm) over nonstructural cracks
- MAPEI's *Reinforcing Fabric* is available but optional for use on coves, corners and field application.

## LIMITATIONS

- *Mapelastic AquaDefense* is not for use over structural cracks, in-plane cracks beyond 1/8" (3 mm) or where vertical out-of-plane movement occurs.
- Do not use over substrates containing asbestos, dimensionally unstable substrates such as hardwood flooring, particleboard, oriented strand board (OSB), Masonite or metal. See "Suitable Substrates" section below.
- Do not use over: Plank flooring, treated plywood, Lauan, gypsum-based floor-patching compounds, vinyl, glazed tile, laminate, fiberglass or epoxy floors, or storage tanks.
- Do not use where excessive substrate moisture and/or where negative hydrostatic pressure exists. Maximum allowable moisture is 8 lbs. per 1,000 sq. ft. (3.63 kg per 92.9 m<sup>2</sup>) per 24 hours per ASTM F1869 or up to 85% relative humidity as measured with moisture probes.
- Do not use: As a single-application roof-deck membrane, wear surface or primary waterproofing membrane on balconies or decks directly over occupied space or in storage tanks; or with premixed setting materials.
- Do not allow direct contact with solvent-based materials.

Consult MAPEI's Technical Services Department for installation recommendations regarding substrates and conditions not listed.

## SUITABLE SUBSTRATES

### Interior and exterior

- Concrete cured for at least 28 days – see the "Limitations" section above
- Masonry walls of cement block or brick
- Cured cement mortar beds or leveling coats
- Cement backer units (CBUs) – see manufacturer's installation guidelines

### Interior only

- Gypsum wallboard (walls only, in approved application areas only)
- Radiant-heated substrates
- Unglazed ceramic tile and cement terrazzo floors, and gypsum underlayments with a minimum of 2,500 psi (17.2 MPa) in compressive strength

Note: Existing unglazed ceramic tile must be abraded, and existing cement terrazzo must be mechanically profiled. Both must be skimcoated with an appropriate MAPEI latex- or polymer-modified mortar.

- Plywood underlayments must be a Group 1 exterior-grade plywood CC-plugged or better, conforming to APA classification and U.S. Product Standard PS 1-95 or a "SELECT" or (SEL-TF) CANPLY classified exterior-grade plywood conforming to CSA-0121 standard for Douglas fir for direct-bond applications

(interior, residential and light commercial floors and countertops in dry conditions only).

- PVC, copper, brass and stainless-steel pipe penetrations (abraded by sandpaper)

---

### **Tile Council of North America (TCNA) Statement on Deflection Criteria**

Floor systems, including the framing system and subfloor panels, over which tile will be installed should be in conformance with the IRC [International Residential Code] for residential applications, the IBC [International Building Code] for commercial applications, or applicable building codes.

Note: The owner should communicate in writing to the project design professional and general contractor the "intended use" of the tile installation, in order to enable the project design professional and general contractor to make necessary allowances for the expected live load, concentrated loads, impact loads, and dead loads including the weight of the tile and setting bed. The tile installer shall not be responsible for any floor framing or subfloor installation not compliant with applicable building codes, unless the tile installer or tile contractor designs and installs the floor framing or subfloor.

---

## SURFACE PREPARATION

- All substrates should be structurally sound, stable, dry, clean and free of any substance or condition that may reduce or prevent proper adhesion.
- Do not use chemicals (acid etching or stripping) to prepare approved substrates.
- Concrete substrates should have a concrete surface profile of #2 per the International Concrete Repair Institute (ICRI). Mechanically clean and profile by diamond-cup grinding or other engineer-approved method when necessary.
- Substrate and room temperatures must be 45°F to 95°F (7°C to 35°C) during and at least 24 hours after application.
- See the "Surface preparation requirements" reference guide in the Tile & Stone Installation Systems section of MAPEI's Website.

## MIXING

Before product use, take appropriate safety precautions. Refer to the Safety Data Sheet for details.

1. Mix by hand before using.
2. Do not dilute with any other material.
3. Promptly wash tools with water after mixing.

## PRODUCT APPLICATION

Read all installation instructions thoroughly before installation.

- Fill all cracks, control joints and gaps in corners and coves that are greater than 1/32" (1 mm) with an appropriate filler material. Force material into crack and finish smooth with trowel. Let dry.
- MAPEI's optional *Reinforcing Fabric* may be used with *Mapelastc AquaDefense* in any of the areas shown below (see the "Optional Use of MAPEI's *Reinforcing Fabric*" section below).
- MAPEI's *Mapeband* accessories (cove roll and drain flashing) also may be used with *Mapelastc AquaDefense* in any of the areas shown below (see the "Optional Use of *Mapeband* Accessories" section below).

### Pre-treat cracks, corners and coves (floor/wall intersections)

1. For expansion and control joints, see the "Expansion and Control Joints" section below.
2. Apply *Mapelastc AquaDefense* liquid 6" (15 cm) on both sides of cracks, corners and coves with a paintbrush or roller. Let dry to a light-green color.
3. Apply a second coat and let dry.

### Pre-treat drains

1. Review drain manufacturer's instructions for waterproof membrane installation in conjunction with these instructions.
2. Fill space between drain pipe and substrate with appropriate expansion joint materials (typically foam backer rod and sealant).
3. For drains with bolt-down collar and weep holes, loosen and remove bolts from drain flange. Abrade drain flange with sandpaper, and clean and dry thoroughly.
4. With paintbrush, apply a liberal coat over and around drain flange. Let dry to a light-green color.
5. Apply a second coat and let dry.

### Pre-treat openings around pipes and other penetrations

1. Pack/fill the openings/spaces between drain pipe and substrate with appropriate expansion joint materials (typically foam backer rod and sealant).
2. Apply *Mapelastc AquaDefense* with brush around and up onto floor or wall penetration. Let dry to a light-green color.
3. Apply a second coat and let dry.

### Complete the main area

1. Apply *Mapelastc AquaDefense* to the entire area to be waterproofed (including previously coated areas such as cracks, drains and penetrations) using a 3/8" (10 mm) nap roller. Let dry to a light-green color.

2. Apply a second coat to the entire installation. Let dry 30 to 50 minutes before installing tile or stone.
3. Final dry thickness of first and second coats combined in the main area should be about 20 mils at minimum (about the thickness of a credit card).
4. Inspect and, as needed, recoat pinholes or areas not completely covered. Let dry.
5. Apply bead of silicone or urethane sealant around drain flange at drain throat to join *Mapelastc AquaDefense* to the drain assembly. Leave no voids.
6. Bolt down collar to drain flange.
7. Where the *Mapelastc AquaDefense* coating ends on any penetration, apply a bead of silicone or urethane sealant.

## CLEANUP

- Remove excess *Mapelastc AquaDefense* (while fresh) with damp sponge, soap and warm water. Any completely dried material may be mechanically removed.

## PROTECTION

- Protect from foot traffic, rain and freezing for 24 hours.
- Protect installed *Mapelastc AquaDefense* from contamination, excessive heat and extended sun exposure until tile or stone is installed.

## FLOOD-TESTING (per ASTM D5957)

If flood-testing is required, allow *Mapelastc AquaDefense* to cure at least 12 hours at 73°F (23°C) and 50% relative humidity. Actual curing time depends on air and substrate temperature, substrate porosity and humidity. Expect shorter drying times in warmer conditions, and longer drying times in cooler conditions.

## INSTALLING CERAMIC TILE OR NATURAL STONE

1. *Mapelastc AquaDefense* is ready to receive thin-set mortars for tile or stone when dry to touch (about 30 to 50 minutes after applying second coat).
2. Let *Mapelastc AquaDefense* cure for at least 8 hours before installing large-and-heavy-tile mortars (for large tile or stone), screeds (for leveling floors) or epoxy adhesives.
3. For tile and stone installations, use a MAPEI polymer-modified mortar meeting ANSI A118.4, ANSI A118.11 or ANSI A118.15, or an epoxy mortar meeting ANSI A118.3. For the installation of resilient or wood flooring over *Mapelastc AquaDefense*, adhere to the adhesive recommendations or limitations for use over nonporous substrates.

Mapelastc  
**AquaDefense**

## EXPANSION AND CONTROL JOINTS

### Installation with Mapeband:

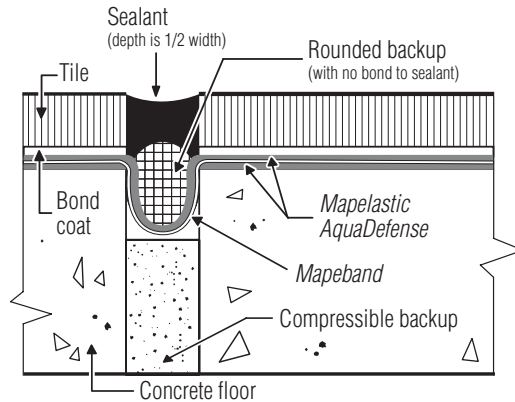

### Installation with MAPEI's Reinforcing Fabric:

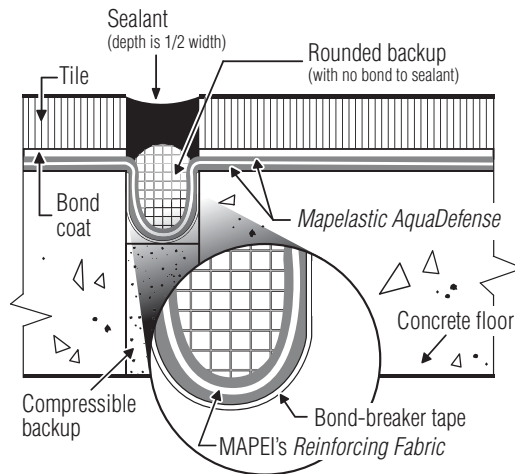

1. Provide for expansion and control joints as specified per TCNA Method EJ171 or TTMAC Specification Guide 09 30 00, Detail 301EJ. Do not cover expansion joints with mortar.
2. If waterproofing integrity is required in expansion and control joints, provide per the above drawing. MAPEI's *Reinforcing Fabric* or *Mapeband* can be embedded into the *Mapelastic AquaDefense* liquid, allowed to dry and filled with appropriate joint sealant or an expansion molding system.
3. Protect tilework with metal strips (edge metal) along both edges of structural building expansion joints.

Contact MAPEI's Technical Services Department for more information.

### OPTIONAL USE OF MAPEI'S REINFORCING FABRIC

#### Select fabric size (see packaging chart)

- For coves (floor/wall intersections), allow for 2" (5 cm) of fabric on the floor and 4" (10 cm) up the wall. For

cracks, control joints and vertical corners, allow for 3" (7.5 cm) of fabric on each side.

- For drains, cut desired fabric size from 38" (97-cm) wide roll. For floor or wall penetrations, use 6" (15-cm) wide, 38" (97-cm) wide or a combination of both.
- For large areas, the 38" (97-cm) wide roll is recommended.

#### Cut fabric to size

- Cut all required pieces. Set aside.

#### Pre-treat cracks, control joints, corners, coves, drains, and floor and wall penetrations

1. Apply *Mapelastic AquaDefense* as described in the "Pre-treat" sections above.
2. Lay pre-cut pieces of fabric into wet *Mapelastic AquaDefense*. Use brush to press fabric into corners until liquid comes through fabric. Work out any wrinkles or bubbles.
3. While fabric is wet, apply additional *Mapelastic AquaDefense* over fabric until completely covered to create void-free surface. Let dry to a light-green color.
4. Apply a second coat and let dry.

#### Install fabric on main area

1. Apply the first coat of *Mapelastic AquaDefense* (including areas previously coated) using a 3/8" (10-mm) nap roller.
2. Place fabric into wet liquid on the floor. Using a roller, apply pressure to the fabric, working out wrinkles or bubbles while forcing *Mapelastic AquaDefense* to come through the fabric. Overlap seams and ends of the fabric by 2" (5 cm). While fabric is still wet, apply additional *Mapelastic AquaDefense* over the fabric until completely covered, creating a void-free surface. Let dry completely to a light-green color.
3. Apply a second coat of *Mapelastic AquaDefense* to the entire area. Let dry.
4. Give a final inspection, looking for pinholes, areas not completely covered and other defects.
5. Recoat as needed. Let dry to a light-green color.
6. Apply a bead of commercial-grade silicone or urethane sealant between the membrane and the drain flange, about 1/2" (12 mm) in from the drain opening.
7. Bolt the drain collar into place while the sealant is still fresh.
8. Install ceramic tile or natural stone per the "Installing ceramic tile or natural stone" section above.

### OPTIONAL USE OF MAPEBAND ACCESSORIES

- MAPEI's *Mapeband* accessories (cove roll and drain flashing) are waterproof, vapor-proof thin, elastic, deformable, rubber-coated fabric pieces that are fully compatible with *Mapelastic AquaDefense* and provide

## Product Performance Properties

Laboratory Tests	Results
pH	9
Viscosity	Approximately 30,000 cps
Density	1.3 g per mL
Weight	10.9 lbs. per U.S. gal. (1.3 kg per L)

## Shelf Life and Product Characteristics before mixing

Shelf life ( <i>Mapelastic AquaDefense</i> )	2 years when stored in original, unopened packaging at 73°F (23°C)
Physical state	Liquid
Color	Light bluish green when wet; light green when dry
Shelf life (optional Reinforcing Fabric)	Unlimited when stored in original, unopened packaging at 73°F (23°C)
Storage	Store in a cool, dry place.

Protect containers from freezing in transit and storage. Provide for heated storage on site and deliver all materials at least 24 hours before work begins.

## Application Properties at 73°F (23°C) and 50% relative humidity

Flash point (Seta flash)	Nonflammable
VOCs (Rule #1113 of California's SCAQMD)	0 g per L
VOCs (CDPH Standard Method v1.2-2017, CA 01350)	Passed
Drying time between first and second coats	When light green and dry to the touch
Drying time after second coat (before applying ceramic tile or stone)	About 30 to 50 minutes (when light green and dry to the touch)
Drying time before flood-testing	After 12 hours
Final dry thickness (2 coats)	About 20 mils at minimum (about credit-card thickness)
Freeze/thaw stability (liquid)	Up to 5 cycles at 32°F (0°C)

## Packaging (*Mapelastic AquaDefense*)

Size	Approximate Coverage (per 2 coats)*
Pail: 1 U.S. gal. (3.79 L) – 4-pack	60 sq. ft. (5.57 m <sup>2</sup> )
Pail: 3.5 U.S. gals. (13.2 L)	210 sq. ft. (19.5 m <sup>2</sup> )
Pail: 5 U.S. gals. (18.9 L)	300 sq. ft. (27.9 m <sup>2</sup> )
Drum: 55 U.S. gals. (208 L) – special order	3,300 sq. ft. (307 m <sup>2</sup> )

\* Coverage shown is for estimating purposes only. Actual jobsite coverage may vary according to substrate conditions, concrete profile and porosity, type of equipment used, thickness applied, handling and application procedures.

## Packaging (optional *Reinforcing Fabric*)

Size	Coverage
Roll: 6" x 75' (15 cm x 22.9 m), 8 per box – To reinforce over cracks, control joints, corners, coves and floor/wall penetrations	37.5 sq. ft. (3.48 m <sup>2</sup> ) per roll
Roll: 38" x 75' (97 cm x 22.9 m), 1 per box – To reinforce around drains or main area to be waterproofed	237.5 sq. ft. (22.1 m <sup>2</sup> ) per roll

## Packaging (*Mapeband* waterproofing accessories)

Size and Color
Drain flashing (blue): 16.75" x 16.75" (43 x 43 cm)
Cove roll (blue): 4.75" x 163 ft. (12 cm x 49.7 m)

# Mapelastick AquaDefense



Continued from Page 4

the ultimate in “change-of-plane” waterproofing protection for coves, corners and drains. *Mapeband* accessories are ideal for environments requiring waterproofing but also where temperature extremes, freeze/thaw conditions, vibrations, etc., can cause waterproofing problems.

- *Mapeband* cove roll can be used in place of MAPEI’s *Reinforcing Fabric* on coves, corners and control joints. The “felt side” should face into the corner.
- *Mapeband* drain flashing can be used in place of MAPEI’s *Reinforcing Fabric* on drains. The “felt side” should face down.
- See *Mapeband*’s Technical Data Sheet for installation details.

## RELATED DOCUMENTS

Reference guide: “Surface preparation requirements” for tile and stone installation systems\*

\* At [www.mapei.com](http://www.mapei.com)

Refer to the SDS for specific data related to health and safety as well as product handling.

For information on MAPEI’s commitment to sustainability and transparency, as well as how MAPEI products may contribute to green building standards and certification systems, contact [sustainability\\_USA@mapei.com](mailto:sustainability_USA@mapei.com) (USA) or [sustainability-durabilite@mapei.com](mailto:sustainability-durabilite@mapei.com) (Canada).

## LEGAL NOTICE

The contents of this Technical Data Sheet (“TDS”) may be copied into another project-related document, but the resulting document shall not supplement nor replace requirements per the TDS in effect at the time of the MAPEI product installation. For the most up-to-date TDS and warranty information, please visit our website at

[www.mapei.com](http://www.mapei.com). **ANY ALTERATIONS TO THE WORDING OR REQUIREMENTS CONTAINED IN OR DERIVED FROM THIS TDS SHALL VOID ALL RELATED MAPEI WARRANTIES.**

Before using, the user must determine the suitability of our products for the intended use,

and the user alone assumes all risks and liability. **ANY CLAIM SHALL BE DEEMED WAIVED UNLESS MADE IN WRITING TO US WITHIN FIFTEEN (15) DAYS FROM DATE IT WAS, OR REASONABLY SHOULD HAVE BEEN, DISCOVERED.**

We proudly support the following industry organizations:



TTMAC ACTTM



**MAPEI Headquarters of North America**  
1144 East Newport Center Drive  
Deerfield Beach, Florida 33442  
1-888-US-MAPEI (1-888-876-2734) /  
(954) 246-8888

**Technical Services**  
1-800-992-6273 (U.S. and Puerto Rico)  
1-800-361-9309 (Canada)

**Customer Service**  
1-800-42-MAPEI (1-800-426-2734)

**Services in Mexico**  
0-1-800-MX-MAPEI (0-1-800-696-2734)

**Edition Date:** February 5, 2021  
MK 3002103 (21-1225)

For the most current product data and BEST-BACKED™ warranty information, visit [www.mapei.com](http://www.mapei.com).

All Rights Reserved. © 2021 MAPEI Corporation.

**Distributed by:**

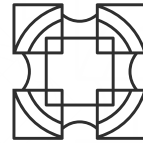

**MALINE TILE**  
ELEVATE YOUR SHOWROOM

**Maline Massachusetts**

Phone: 781.792.1780  
Email: [SalesMA@maline.com](mailto:SalesMA@maline.com)  
20 Reservoir Park Drive, Rockland, MA 02370

**Maline New Jersey**

Phone: 973.835.0244  
Email: [SalesNJ@maline.com](mailto:SalesNJ@maline.com)  
2 Doig Road, Wayne, NJ 07470



For more questions & information email [info@maline.com](mailto:info@maline.com)

[malinetile.com](http://malinetile.com)